

# LINO 90, 120, 150

A. Suspension | Pendelleuchte | Závěsná | Závesná

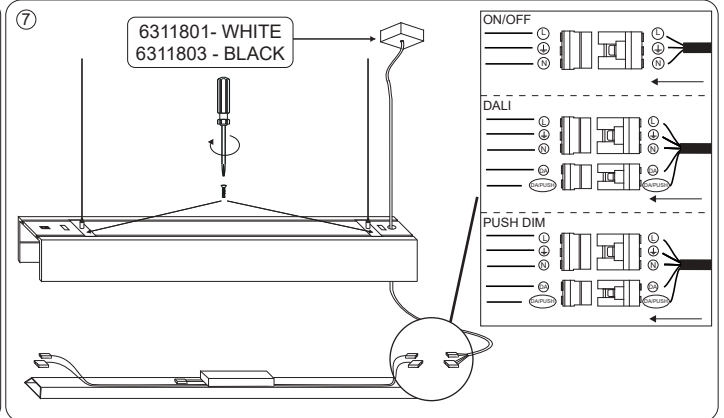
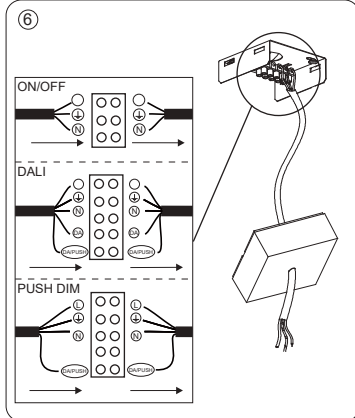
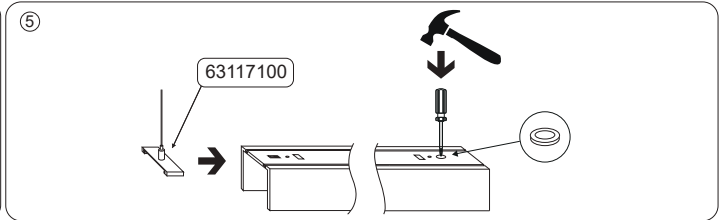
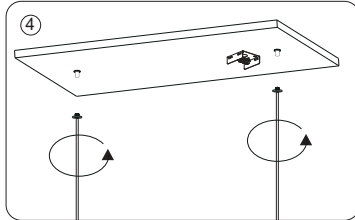
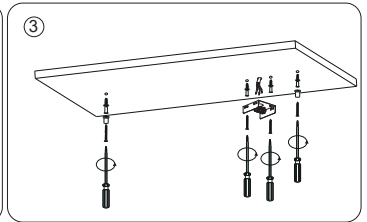
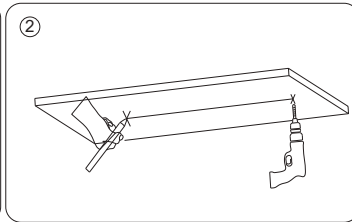
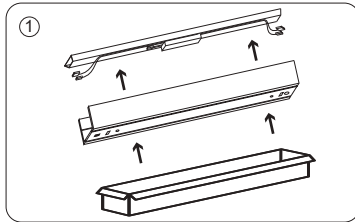

Current selection by DIP-switch

LINO 90					
Pin1	Pin2	Pin3	Pin4	Currents (mA)	W
OFF	OFF	OFF	OFF	300	12
ON	OFF	OFF	OFF	350	14
ON	ON	OFF	OFF	400	16
ON	ON	ON	OFF	450	18
ON	ON	ON	ON	500	20

LINO 120					
Pin1	Pin2	Pin3	Pin4	Currents (mA)	W
OFF	OFF	OFF	OFF	550	22
ON	OFF	OFF	OFF	600	24
ON	ON	OFF	OFF	650	26
ON	ON	ON	OFF	700	28
ON	ON	ON	ON	750	30

LINO 150					
Pin1	Pin2	Pin3	Pin4	Currents (mA)	W
OFF	OFF	OFF	OFF	800	31
ON	OFF	OFF	OFF	850	33
ON	ON	OFF	OFF	900	36
ON	ON	ON	OFF	950	37
ON	ON	ON	ON	1000	39



**! ONLY FOR P/N - DIRECT/INDIRECT VERSION !  
INSTALLING INDIRECT LED BOARD**

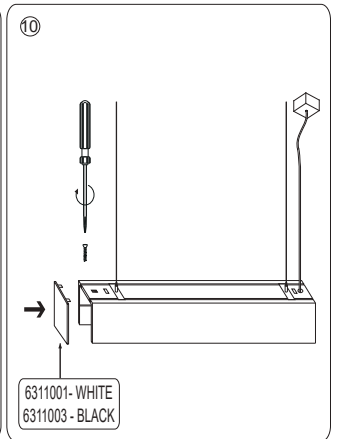
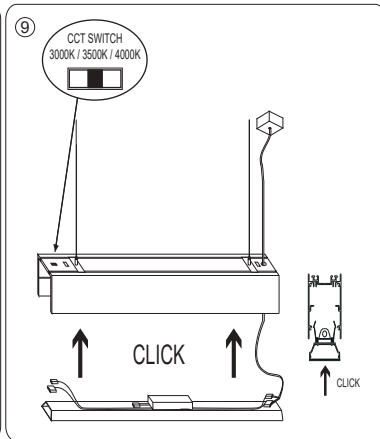

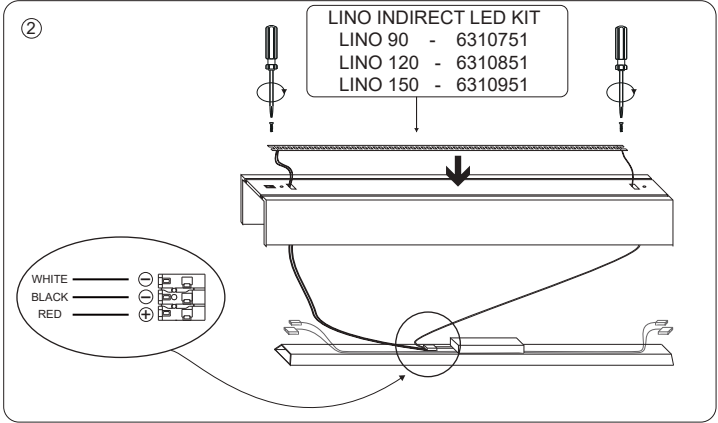
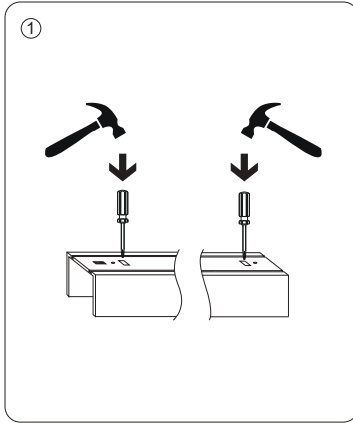
**B. Surface | Deckenleuchte | Stropní | Stropná**

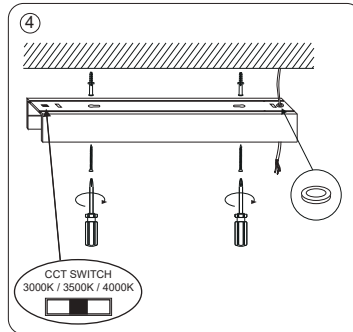
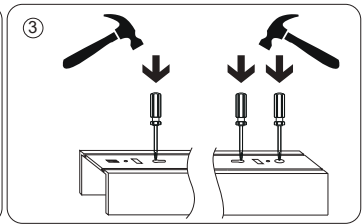
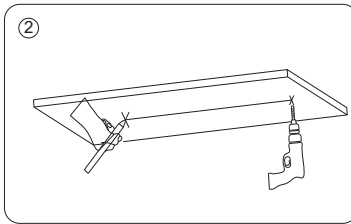
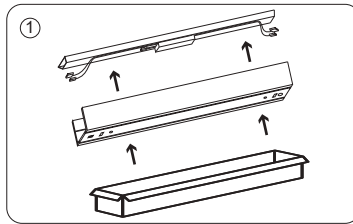

⑤

Current selection by DIP-switch

LINO 90						
Pin1	Pin2	Pin3	Pin4	Currents (mA)	W	
OFF	OFF	OFF	OFF	300	12	
ON	OFF	OFF	OFF	350	14	
ON	ON	OFF	OFF	400	16	
ON	ON	ON	OFF	450	18	
ON	ON	ON	ON	500	20	

LINO 120						
Pin1	Pin2	Pin3	Pin4	Currents (mA)	W	
OFF	OFF	OFF	OFF	650	22	
ON	OFF	OFF	OFF	650	24	
ON	ON	OFF	OFF	650	26	
ON	ON	ON	OFF	700	28	
ON	ON	ON	ON	750	30	

LINO 150						
Pin1	Pin2	Pin3	Pin4	Currents (mA)	W	
OFF	OFF	OFF	OFF	800	31	
ON	OFF	OFF	OFF	850	33	
ON	ON	OFF	OFF	900	35	
ON	ON	ON	OFF	950	37	
ON	ON	ON	ON	1000	39	

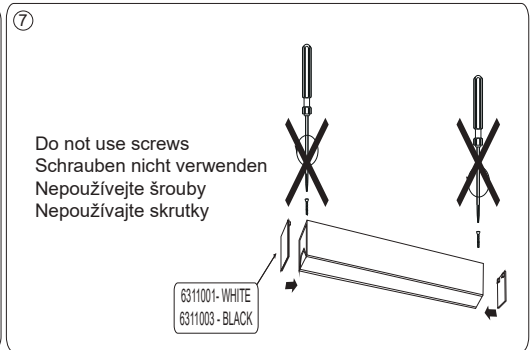
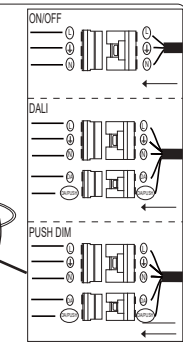
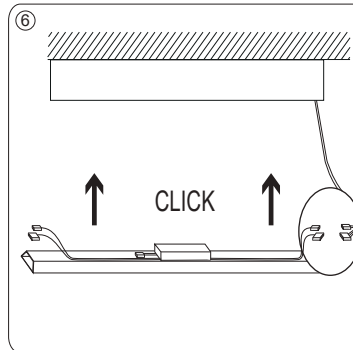

# C. Continuous connection | Kontinuierliche Verbindung Spojování modulů | Spájanie modulov

- ① **!** Align profile with hole in the connector | Profil mit Loch im Verbinder ausrichten  
Zarovnejte profil s otvorem ve spojce | Zarovnajete profil s otvorom v spojke

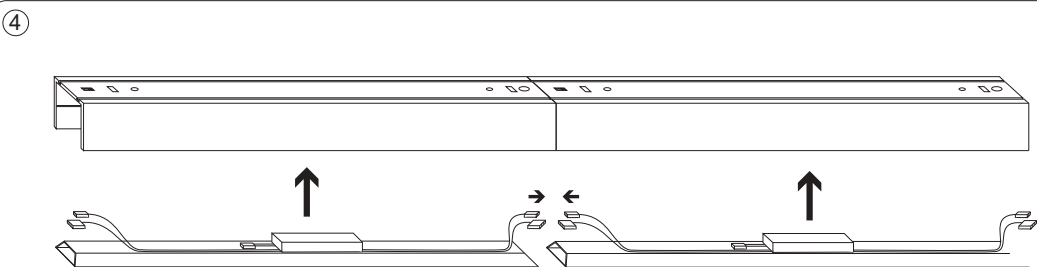
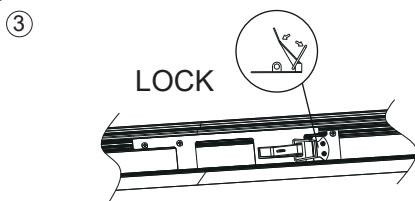
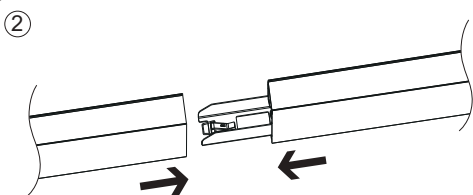
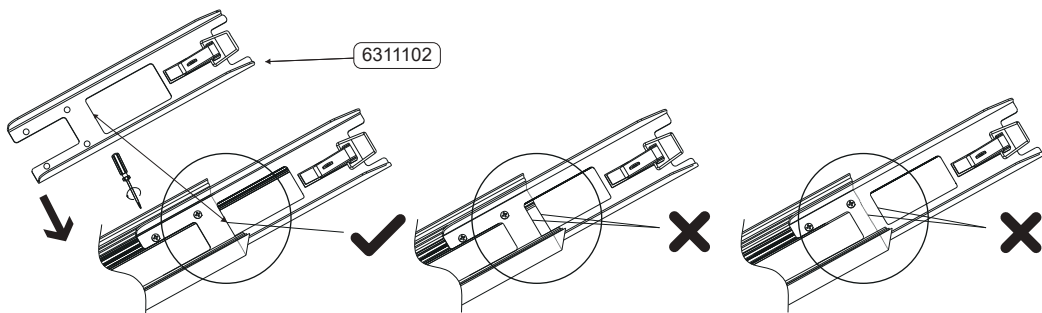

---

**(SK) UPOZORNENIE!**

Pred inštaláciou je nevyhnutné odpojiť hlavný elektrický okruh, aby ste predišli zasiahnutiu elektrickým prúdom. Montáž môže vykonať iba kvalifikovaná osoba. V prípade, že má svetidlo tienidlo/difúzor, narábajte s ním opatrne, pretože je krehké. Pri integrovanom LED svetelnom zdroji môže výmenu zrelizovať iba technik alebo kvalifikovaná osoba. Výrobca nenesie zodpovednosť za nesprávne zachádzanie s produktom.

**(CZ) UPOZORNĚNÍ!**

Před instalací je nutné odpojit hlavní elektrický okruh, abyste předešli zasažení elektrickým proudem. Montáž může provádět pouze kvalifikovaná osoba. V případě, že má svítidlo stínidlo/difuzor, zacházejte s ním opatrně, protože je křehké. Při integrovaném LED světelném zdroji může výměnu zrelizovat pouze technik nebo kvalifikovaná osoba. Výrobce nenesie odpovědnost za nesprávné zacházení s výrobkem.

**(EN) CAUTION!**

Turn off the main power before proceeding with the installation in order to prevent possible shock. The installation may only be carried out by a technician or a qualified person. If the lamp has a lampshade/diffuser, handle it carefully as it is fragile. With an integrated LED light source, only a technician or a qualified person can make the replacement. The manufacturer is not responsible for the incorrect use and assembly of its products.

**(DE) ACHTUNG!**

Vor der Installation ist es notwendig, den Hauptstromkreis zu unterbrechen, um ein Stromschlag zu vermeiden. Die Installation darf nur von einem Techniker oder einer qualifizierten Person durchgeführt werden. Wenn die Lampe einen Lampenschirm/Diffuser hat, gehen Sie vorsichtig damit um, da sie zerbrechlich ist. Mit einer integrierten LED-Lichtquelle kann nur ein Techniker oder eine qualifizierte Person den Austausch vornehmen. Der Hersteller ist nicht verantwortlich für die fehlerhafte Verwendung und Montage seiner Produkte.